

Submittal Data: TERRA18HP230V1B 18,000 BTU/H Wall Mounted Heat- Pump System

Job Name Location Date

Purchaser Engineer

Submitted To For Reference Approval Construction

Unit Designation Schedule No.

- GENERAL FEATURES**
- Ultra High Efficiency
 - 7 Indoor Fan Speeds
 - 4 Way Airflow Operation
 - Photocatalytic Filter
 - Wireless Remote with LCD Display
 - Gold Fin Condenser Coil
 - 5 year Limited Parts Warranty
 - 7 year Limited Compressor Warranty



System Ratings

Cooling	
Rated Capacity	18000 BTU/H
Capacity Range	4,600-22,180 BTU/H
Power Input (Max)	2,450 W
SEER	21
EER	12.5

Heating at 47° F	
Rated Capacity	19,000 BTU/H
Capacity Range	3,412-23,202 BTU/H
Power Input (Max)	2,500 W
HSPF	10.0
COP	3.5

Heating at 17° F	
Rated Capacity	12,100 BTU/H
Capacity (Max)	16,363 BTU/H
Power Input (Max)	2,153 W
COP	2.5

Operating Range	
Cooling (Max)	109°F (43 C)
(Min)	5°F (-15 C)
Heating (Max)	75°F (24 C)
(Min)	5°F (-15 C)

Power Supply	
Normal Operational Voltage	208/230 V, 1 Phase, 60 Hz
Voltage Range	187 - 253 V
Main Power Wire Size	12-2 AWG
Interconnecting Cable Wire Size	14-4 AWG
MCA	15 A
MOCP/Breaker Size	20 A

Indoor Unit Data

Fan Motor	Output Power	25 W
	FLA	0.1 A

Airflow	
Cooling Wet (Lo/Hi)	282/589 CFM
Heating Dry (Lo/Hi)	282/589 CFM

Sound Pressure Level	
Cooling (Lo/Hi)	33/51 db(A)
Heating (Lo/Hi)	33/51 db(A)

Dimensions & Weights	
Unit Dimensions (LxHxD)	40.1 x 12.6 x 9.1-in
Weight (Net/Shipping)	31/39 LBS

Outdoor Unit Data

Compressor	DC Inverter Driven Rotary
-------------------	---------------------------

Refrigerant Type	R410A
-------------------------	-------

Fan Motor	Output Power	60 W
	FLA	0.5 A

Sound Pressure	
Cooling (Lo/Hi)	56/66 db(A)
Heating (Lo/Hi)	56/66 db(A)

Dimensions & Weights	
Unit Dimensions (LxHxD)	37.6 x 27.6 x 15.6-in
Weight (Net/Shipping)	108/118 LBS

Refrigerant Piping Data	
Gas Pipe Size (OD)	5/8-in
Liquid Pipe Size (OD)	1/4-in
Connection Method	Flared
MAX Refrigerant Pipe Length	82-ft
MIN Refrigerant Pipe Length	10-ft
MAX Refrigerant Pipe Height Difference	33-ft



EXTENDED RATINGS

COOLING PERFORMANCE

Outdoor Ambient Temperature (DB)	Indoor Entering Air Temperatures (DB) 50% RH					
	62 F		67 F		72 F	
	TC	SHC	TC	SHC	TC	SHC
25 F	NA	NA	NA	NA	NA	NA
35 F	NA	NA	NA	NA	NA	NA
45 F	NA	NA	NA	NA	NA	NA
55 F	20,681	16,007	22,006	16,504	23,591	17,222
65 F	19,761	15,354	21,695	16,467	23,005	16,816
75 F	18,788	14,692	20,198	15,533	21,926	16,181
85 F	17,846	14,170	19,080	14,730	20,906	15,617
95 F	16,776	13,404	18,000	14,382	19,872	14,924
105 F	15,908	12,917	17,096	13,643	18,750	14,400
115 F	15,051	12,402	15,923	12,898	17,168	13,443

HEATING PERFORMANCE

Outdoor Ambient Temperature (DB) (80% RH)	Indoor Entering Air Temperatures (DB)					
	65 F		70 F		75 F	
	TC	SHC	TC	SHC	TC	SHC
5 F	16,438	16,438	15,514	15,514	15,134	15,134
15 F	17,571	17,571	16,030	16,030	15,934	15,934
25 F	18,643	18,643	17,695	17,695	16,688	16,688
35 F	19,684	19,684	18,219	18,219	17,455	17,455
45 F	20,713	20,713	20,010	20,010	18,798	18,798
55 F	20,740	20,740	20,140	20,140	19,259	19,259
65 F	20,642	20,642	20,340	20,340	19,714	19,714

TC- Total Capacity (BtuH)

SHC- Sensible Capacity (BtuH)



MINIMUM SPACING REQUIREMENTS

Units: inch (mm)

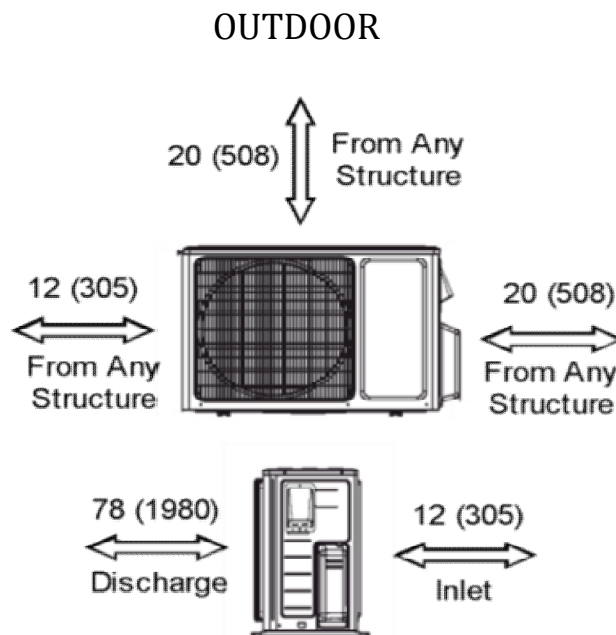
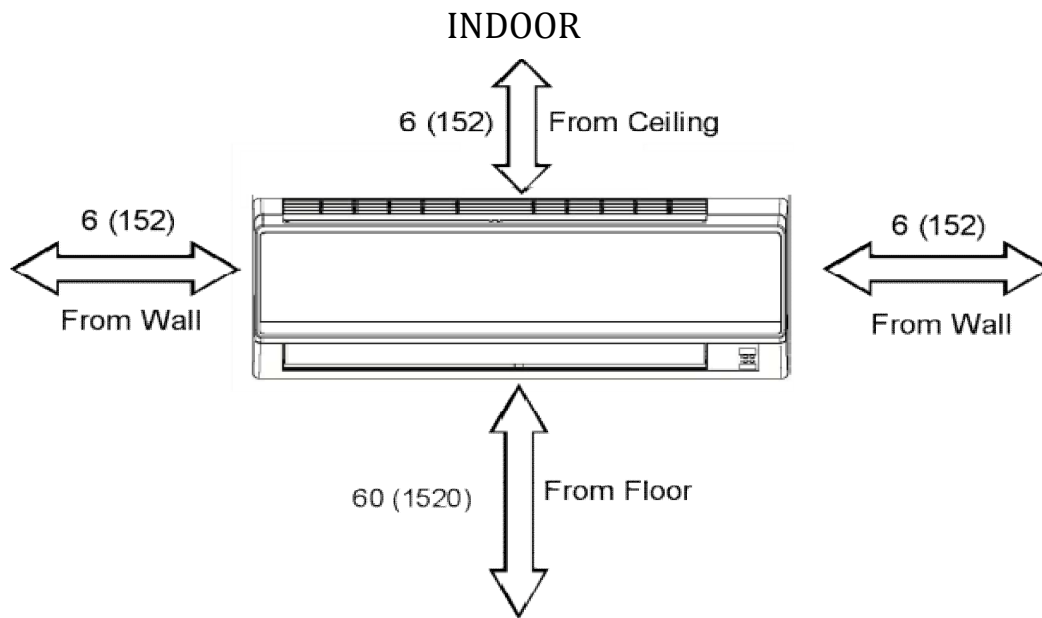

DIMENSIONAL SPECIFICATIONS

TERRA18HP230V1B

INDOOR UNIT DIMENSIONS

Units: inch (mm)

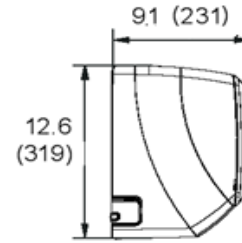
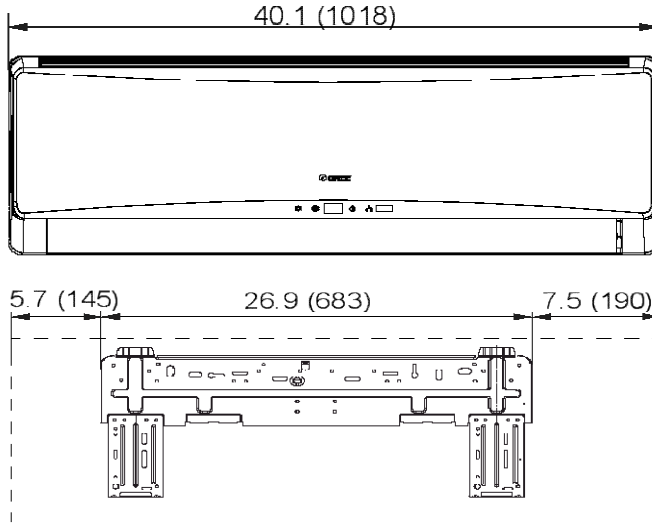

Liquid Line Valve	1/4-in OD Flared
Gas Line Valve	5/8-in OD Flared
Drain Connector	5/8-in OD

OUTDOOR UNIT DIMENSIONS

Units: inch (mm)

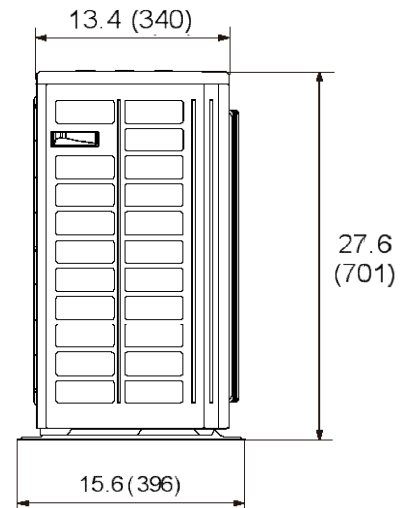
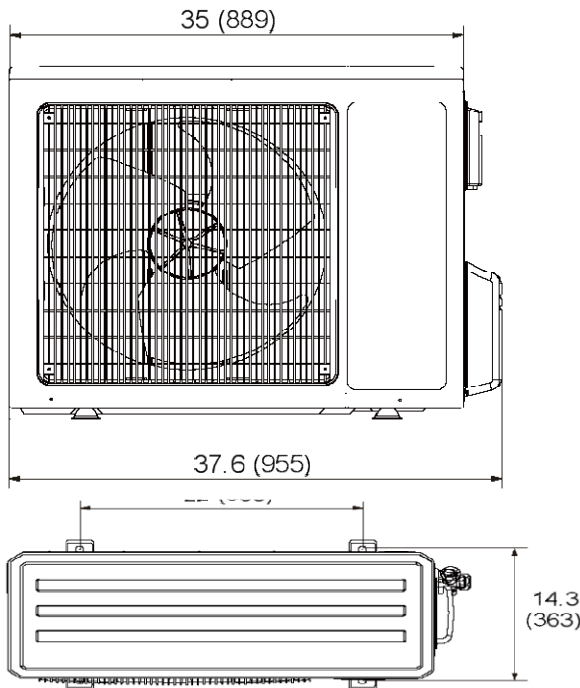

Liquid Line Valve	1/4-in OD Flared
Gas Line Valve	5/8-in OD Flared

Notes:

1. Recommended Interconnecting Cable Type Stranded Bare Copper Conductors THHN 600V Wire
2. Power wiring cable size must comply with applicable national and local codes.
3. Test conditions are based on AHRI 210/240.

Distributed by: **boreal**
INTERNATIONAL

GREE
Change for Life

www.greecomfort.com

Specifications are subject to change without notice. Manufacturer reserves the right to discontinue or modify specifications or designs without notice or without incurring obligations. All rights reserved.